



The 8th International Conference on Applied Energy – ICAE2016

Exploring Piezoelectric for Sound Wave as Energy Harvester

Liew Hui Fang^a, Syed Idris Syed Hassan^a, Rosemizi Abd Rahim^b, Muzamir Isa^a
Baharuddin bin Ismail^c

^a*School of Electrical System Engineering, Universiti Malaysia Perlis, Pauh Putra Campus, 02600, Arau, Perlis, MALAYSIA*

^b*School of Computer and Communication Engineering, Universiti Malaysia Perlis, Pauh Putra Campus, 02600, Arau, Perlis, MALAYSIA*

^c*Center of Excellence for Renewable Energy (CERE) Universiti Malaysia Perlis, Pauh Putra Campus, 02600, Arau, Perlis, MALAYSIA.*

Abstract

This paper presents the characteristic of piezoelectric for sound wave energy harvester. The sound level on piezoelectric is experimented at range of 35-100 dB. This range is comparable with ambience environmental human sound of level 50-100 dB. Piezoelectric type Q220-A4-503YB has been used as energy transducer. This type of piezoelectric has achieved a better performance in term of output power or voltage. The output of piezoelectric transducer is connected to 3 difference types of harnessing circuitry; Villard voltage multiplier, Dickson voltage multiplier and full-wave rectifier. The measured results of piezoelectric transducer with and without connected to external circuitry devices have attained a good agreement with expected theory within the frequency of interest. The piezoelectric transducer accomplished maximum power response of performance 33.133 dBuW at sound level of 96 dB. The Villard and Dickson voltage multipliers produced output voltage greater than full wave bridges which are 9.817V, 9.593V and 3.504V respectively at 96dB sound intensity level. The results show that the piezoelectric transducer connected to Villard voltage multiplier produced the best performance. The proposed sound wave energy harvester offer a better performance and able to replace the problematic battery in wireless signal network.

© 2017 The Authors. Published by Elsevier Ltd. This is an open access article under the CC BY-NC-ND license (<http://creativecommons.org/licenses/by-nc-nd/4.0/>).

Peer-review under responsibility of the scientific committee of the 8th International Conference on Applied Energy.

Keywords: Piezoelectric material; Sound wave; Energy harvesting; Piezoelectric transducers; Voltage multiplier; Harvesting circuitry

1. Introduction

Energy harvesting system is important in solving a short run-time for a device or battery life by prolonged life of electronic devices [1, 2]. Due to lifecycle of battery is limited and the remote locations of a large number of sensors, consequential in higher maintenance cost are needed. Therefore, its normal operation will be interrupted whenever the supplying batteries are out. Besides, there are some other determinations to develop on energy harvesting technology such as noise reduction, elimination of cross-talks, and all these power sources are renewable, hygienic, and available limitlessly in the environment [3-6]. Energy harvesting can be obtained from different energy sources, such as mechanical vibration electromagnetic, light, wind and temperature variations [7-14]. The energy is freely obtainable in

environment complementing the low power sources used for energizing the low power electronic devices, as an application to green technology. For sound wave energy harvesting, it is proposed to use a vibration mechanism. The sound produces mechanical energy which then converts to electrical energy using a transduction mechanism, such as electromagnetic (inductive), electrostatic (capacitive) or piezoelectric [15-18]. Most harvesters practically in usable forms can provide low output power, and needs integrate circuit to harness the higher output power then stored into some applications. Based on literature review, piezoelectric elements especially Lead-zirconate-titanate (PZT) is suitable to be used for harvesting ambient mechanical energy and converts into usable electricity [20]. Piezoelectric materials are naturally used for energy harvesting from ambient vibration sources, because they can proficiently convert mechanical strain to an electrical charge without any extra power and has a simple mechanical structure.

Previous works discovered that the electrical output from of piezoelectric devices unable to applied directly to some applications since the output power is much lower. For this consequence, there are some circuits have been used to improve the electrical output of piezoelectric devices, such as circuits in Ottman et al. [21]. He had described an approach to harvesting electrical energy from a mechanically excited piezoelectric element. In this circuit, the energy can be stored by using a full-wave rectifier. Ottman analyzed the optimal power flow of piezoelectric device, but the efficiency of energy harvester unable to achieve the maximum point. Liu et al. [22], presented a power management circuit based on matching the source impedance and switched-capacitor network, but in low frequency applications. The matching circuit can maximize the stored power, and the frequency conversion circuit can make the system much smaller. An investigation conducted by Kwon et. al. [23], is to improve the performance and efficiency of energy harvesting. He proposed a piezoelectric energy harvesting circuit with CMOS design to avoid extra losses and low voltage restrictions problem with a rectifier. This is done by transferring and extracting energy directly from piezoelectric transducer to the battery via switched inductor. Experimental results show that the efficiency of the proposed system can harvest energy by 71% and 69% from 3V and 1.5V peak piezoelectric voltages, respectively.

Due to its prevalence in urban environments, Ssound energy becomes has very attractive as a possible energy resource to harvest. Efficient ways in harvesting the environmental noise into electrical energy is a big challenge since the acoustic energy comes from its low power density. Therefore, sound wave energy harvesting has created excessive attention among the researchers, scientists and engineers. Main profits of the sound wave energy harvesting system is that its involved minimum maintenance which suitable to be arranged in large scale or previously inaccessible locations. Sound energy is available in some circumstances such as, airports, construction sites, factory, etc. It is hygienic and supportable energy source. Investigating of sound energy becomes a great concern to transform the ambient energy into practical and usable electrical energy.

The objective of this research is to develop a piezoelectric energy harvesting system from sound wave. The main design is to harness the acoustics energy in environment and turn it into electricity to power up micro circuits. One of the major issues that arise when using power harvesting devices is that the energy produced from piezoelectric materials is far too small to power most electronic devices. Therefore, methods of accumulating the energy must be developed to allow the piezoelectric to be used as a power supply. Hence, techniques to increase the amount of energy generated by the energy harvesting device are evolving in new and advanced methods of storing the energy are necessary such as include step-up transformers, voltage-doubler, multiplier circuits, charge pump circuits, switched-capacitor circuits, and boost or step-up converters [24-27]. Therefore, several efficiency piezoelectric energy harvesting interface circuits have been identified which normally used to extract power out from piezoelectric energy harvesters.

2. Concept of Sound Harvester

In this experiment, the few types of piezoelectric transducer are be characterized and selected to achieve resonant frequency which less than 1 kHz based on compatibility with low frequency ambient sources vibration. Piezoelectric material types used in this research study include Q220-A4-202YB, Q220-A4-303YB, Q220-A4-503YB, D220-A4-303YB, D220-A4-503YB and EH220-A4-503YB. Several interface methods are explored in order to extract power from piezoelectric material which includes full-bridge rectifier and voltage multiplier circuit.

Full-bridge rectifier and voltage multiplier are normally used to convert the ac output of a piezoelectric harvester into dc voltage. Full-bridge rectifier and voltage multiplier circuits were constructed using the capacitor and diodes design platform. A full-wave bridge rectifier is very efficient, converting positive and negative cycles from piezoelectric transducer and converts to d.c voltage. It is unique because its formation allows the negative portion of the input signal to follow the same current path as when it does during the positive input signal. The output voltage of full wave rectifier is 0.637 V of voltage peak value.

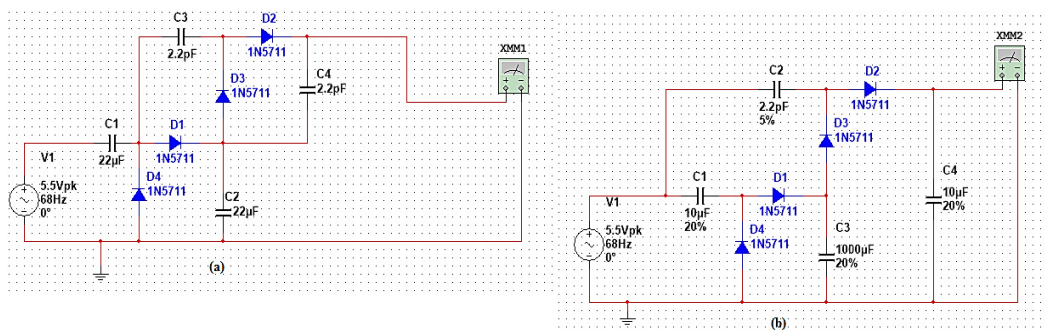

Fig 1. (a) Villard multiplier and (b) Dickson multiplier

The other two types such as Villard and Dickson voltage multipliers are shown in Fig 1 (a) and 1 (b), respectively. They have same function as the rectifier in the sense that only the positive portion of the ambient signal is used. 1N5817G schottky diode has been used into rectifier and voltage multipliers designed since it has the lower forward voltage drop. Small voltage drop will allow as minimum as possible the sound wave to be harvested. The voltage multiplying is achieved when the first capacitor and first diode act just as a half wave rectifier during the positive portion of the input signal. When the input signal becomes negative, first diode is in reverse biased and the second is in forward biased allowing the first capacitor to aid in charging the storage capacitor and creating a voltage equal to multiple inputs.

The existing cascade voltage multiplier can harvest an output voltage higher than the applied input voltage. However, a new circuit structure that can deliver a higher DC output voltage with lower ripple and faster output settling-time is in demand.

3. Methodology

In order to design the piezoelectric for sound wave as energy harvester, two important stages are introduced. First, a sound transducer is developed which is able to harvest the sound wave energy and convert it into a useful electrical energy. This is accomplished by capturing sound wave energy from the source such as speaker and converting the signal by using piezoelectric which acts as an energy transducer. Second stage, an interface circuit is used to increase the output power to become useful to end application. This is due to the condition of the signal generated in piezoelectric transducer is low.

3.1 Characterization of Piezoelectric Transducer in term of Output, Current and Power

The experimental setup to measure the characteristic of piezoelectric transducer is shown in Fig 2. Sound wave is generated using function generator and then transmitted via high power loudspeaker. A piezoelectric transducer is placed inside wood absorber from loudspeaker and measured the output using oscilloscope. A sound level meter is located near the piezoelectric transducer in order to determine the sound level intensity at the vicinity. To reach the maximum output of a.c signal, the resonant frequency of the all types piezoelectric materials must be matched with the sound wave applied.

Otherwise, the output will drop significantly. The sound intensity (dB) is also another important parameter that affects the performance of piezoelectric transducer in producing the output signal. Therefore, both parameters will be analyzed to determine the optimum output of a.c signal.

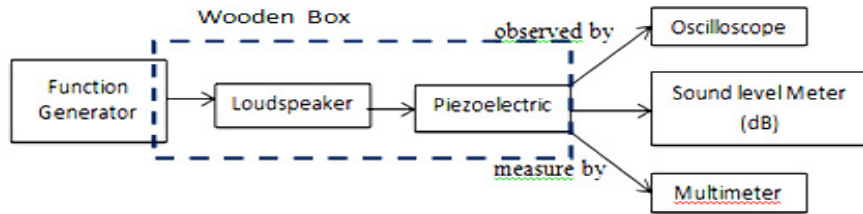

Fig. 2. The experimental setup for characteristics of the piezoelectric transducer harvester on sound wave

3.2 Harvesting Interface Circuitry

Fig 3 presents a block diagram for measuring setup of harvesting circuit with piezoelectric transducer. Rectifier is used to convert the a.c signal from the output of piezoelectric transducer into d.c power and the output results were measured using oscilloscope and multimeter. The sound wave is applied at the similar resonant frequency (68 Hz). The output signal voltage from piezoelectric transducer is amplified by the rectifier or voltage multiplier circuitry.

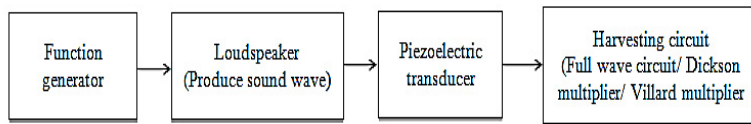

Fig. 3. The block diagram representation of harvesting circuit with piezoelectric transducer.

4. Result and Discussion

4.1 Analysis of Power for Piezoelectric Transducer at 68 Hz

Fig 4 is the result of output power from overall piezoelectric with difference levels of sound intensity. The graph shows that only Q220-A4-503YB and EH220-A4-503YB piezoelectric transducer have higher efficiency output power generated compared to others types. The Q220-503YB can produce the higher output power up to 33dB (uW) and then followed by EH220-A4-503YB which have almost 20 dB (uW). The reason of these two piezoelectric transducers has great output power due to size are large and having biggest surface to harvest energy from loudspeaker. Whereas D220-A4-303YB have 19.146 dB(uW) and D220-A4-203YB have 16.96. The Q220-A4-203YB and Q22-A4-303YB have 250 Hz resonant frequency and output power are 2.143 dB(uW) and 4.8485 dB(uW) respectively. The resonant frequency,

68 Hz is selected for the piezoelectric almost other because it is can capable to produce the higher output voltage. The sound level intensity is varied by adjusting the function generator amplitude.

The piezoelectric transducer Q220-A4-503YB has demonstrated that when the sound level is increased from 60 dB until 85 dB, the piezoelectric output is also linearly increased. When the sound level is 85 dB and above, the output starts saturated which probably due to the stiffness of the piezoelectric material. The maximum output voltage signal of piezoelectric is found to reach a value of around 3.894 V at 96 dB. The output power measured at this point is around 33.1 dBuW. If extra higher sound wave intensity level is applied, it will probably damage the piezoelectric transducer. The graph demonstrates the relationship between the power dB(uW) ranging from -20 to 40 and the sound level (dB).

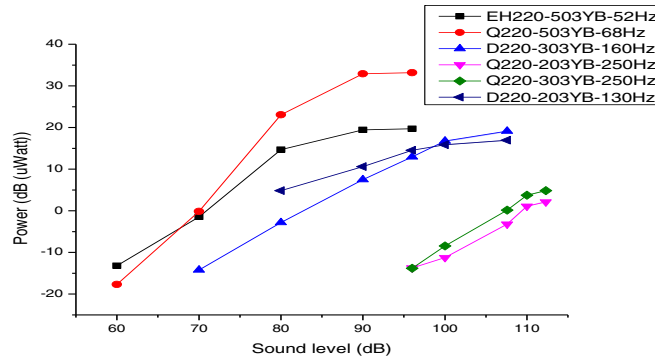

Fig. 4. Graph of power versus sound level for variety type piezoelectric transducer.

4.2 Analysis of Output Voltage for Interface Circuit with Piezoelectric Transducer at 68 Hz

Fig 5(a) shows the outputs of piezoelectric when interface with voltage rectifier or multiplier circuits. The results illustrate that the harvesting circuits start operating when the sound level is more than 75 dB even though the piezoelectric itself can harvest the sound wave as low as 50 dB. This is because the forward threshold voltage for the diode used is 0.45 V. When the piezoelectric is connected to full wave rectifier, the output voltage is 3.504 V at 96 dB sound intensity level of generated wave. Whereas, the Villard and Dickson voltage multiplier are doubling the input from piezoelectric and produced output voltage of 9.817 V and 9.593 V respectively at 96 dB of sound intensity level.

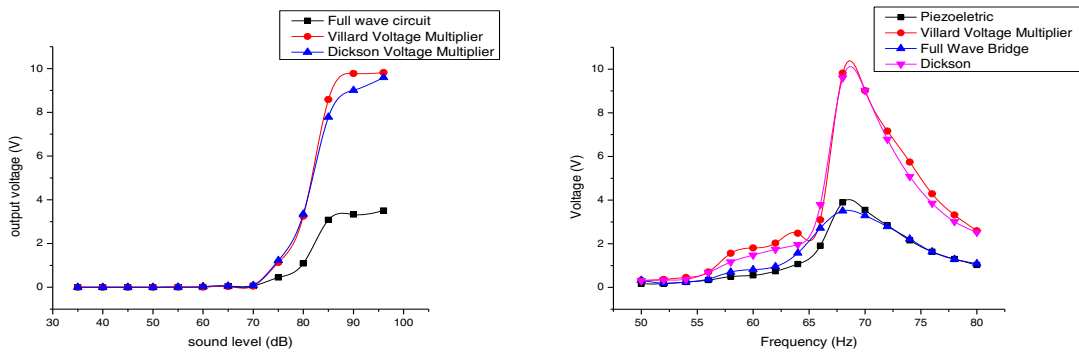

Fig. 5. (a) Output voltage versus sound level after piezoelectric material connect to harnessing circuitry (b) Bandwidth for voltage versus frequency for piezoelectric transducer without and with connected to external circuitry.

4.3 Bandwidth Analysis of Piezoelectric and Its Interface Circuit

Fig 5(b) shows the relationship between the voltage and the frequency with ranging from 50-80 Hz. The test is performed to determine the resonance frequency of the energy harvesting circuit by measuring the output voltages at difference excitation frequencies. The graph represents the bandwidth for voltage versus frequency for piezoelectric material without and with connected to voltage multiplier circuits. From the results in Fig 5(b), it is shown that the bandwidths of piezoelectric transducer without interfacing, full-wave rectifier, Villard voltage multiplier and Dickson voltage multiplier are 6.75Hz, 6.75 Hz, 6.90 Hz and 6.0 Hz, respectively. Generally, the whole bandwidths of piezoelectric transducer Q220-A4-503YB shown in Fig 5(b) are narrow, not too wide and occurred at frequency range between 65-72 Hz. The piezoelectric transducer without and with connected to external circuitry bandwidth only happened at certain frequencies range due to structural design of piezoelectric material shape. In order to increase the bandwidth piezoelectric transducer in future, trapezium shape of piezoelectric transducer is suggested. Overall, the experimental results of interfacing circuit and piezoelectric transducer in Fig 5(b) have accomplished excellent agreement with theoretical theory which has bandwidth identical matching to each other.

4.4 Analysis of Power Conversion Efficiency on Energy Harvesting Interface Circuits

Table 1 demonstrated the analysis of whole experimental results of the power conversion efficiency on energy harvesting interface circuit. The rectifier circuit ratio reaction only start operated when sound level is achieved 80 dB. This is because the requirement of full wave bridge to work is at $0.637 V_m$ or $0.9 V_{rms}$. whereas, at 80 dB, 90 dB and 96 dB, the rectifier circuit have ratio of 0.634, 0.634 and 0.636 respectively. For Villard and Dickson voltage multiplier are designed for 2 stages, i.e as a voltage multiplier circuit which means that the ratio between its output and input must only reach 2 when it is activated. Table 2 shows, at 50 dB to 70 dB, the voltage multiplier circuits are in deactivated condition. Hence, both voltage multipliers are only functioning well at sound level from 80 dB up to 96 dB.

These means that the ratios are in order (close to a range of 2) to enable circuits to activated. Based on Table 1, piezoelectric model has been designed based on commercial frequency setting as demonstrated. Once the values were chosen, the output voltage is measured and compared to the input voltage. Using parametric analysis, an efficient load current is realized and provides a maximum output voltage. Once an optimum load current is found, the efficiency of each circuit is then calculated. In this case, the ratio of the output and the input voltages supplied in the experiment has been determined. The value is calculated based on the ratio of the average of the output voltage over the average of the input voltage during a specific interval of time as in Equations (1) and (2). Once the maximum efficiency is found, the analysis of different efficiencies for different frequencies of piezoelectric is done.

Table 1. Analysis of the power conversion efficiency on energy harvesting with difference interface circuits

Sound level (dB)	Output Piezoelectric		Full wave (rectifier circuit)		Villard voltage multiplier (2-stage)		Dickson voltage multiplier (2-stage)	
	V_{rms} (V)	V_m (V)	V_{out} (V_{dc})	Ratio of conversion	V_{out} (V_{dc})	Ratio of conversion	V_{out} (V_{dc})	Ratio of conversion
50	0.002	0.003	0.002	Not activate	0.005	Not activate	0.005	Not activate
60	0.017	0.024	0.009	Not activate	0.010	Not activate	0.031	Not activate
70	0.094	0.133	0.069	Not activate	0.053	Not activate	0.085	Not activate
80	1.121	1.715	1.087	0.634	3.249	1.894	3.345	1.95
90	3.705	5.239	3.323	0.634	9.773	1.939	9.010	1.72
96	3.894	5.506	3.504	0.636	9.817	1.783	9.593	1.74

$$\text{Ratio of conversion} = V_{\text{out}} / V_m \quad (1)$$

$$V_m = 1.414 V_{\text{rms}} \quad (2)$$

*Where V_m is a voltage peak-peak and V_{out} is an output voltage

5. Conclusions

The results show that the noise energy in ambient environment is successfully harvested and stored by the designed energy harvesting module. Vibrations can be measured in any environment and converted into this equivalent circuit. In this paper, new method of harnessing the piezoelectric energy has been developed. The output power of piezoelectric transducer only extracted at -20 dBuW to 33.3 dBuW, but it is often lowest and not appropriate to power up other devices. Therefore, with a combination of a power source for different interface circuits such as rectifier and voltage multiplier circuit are used in order to extract the ambient energy. The multipliers designed have produced the best results in terms of extracting the most ambient vibrational energy. In order to produce the best proficiency and output power, the circuit has been designed and developed according to the ambient-source, characteristics, PZT materials and load constraints. The energy harvesting system is capable to apprehending even minute amounts of stress and vibrations, then converting them to electric power sufficient to run low-power electronic systems. Piezoelectric transducer 68 Hz analysis shows the capability of harvesting noises available in the ambient environment at low frequency. Hence, employing environmental energy sources as an alternative to electrochemical battery, which has a finite lifespan, can be an excessive advantage to these sources in powering low consumer electronic devices and green environment.

Acknowledgements

The authors acknowledge University Malaysia Perlis and the Center of Excellence for Renewable Energy (CERE), which made it possible to conduct and publish this research.

References

- [1] David Berdy, F., Srisungsthisunti, P., Jung, B., and Peroulis, D. *Low-Frequency Meandering Piezoelectric Vibration Energy Harvester*. IEEE Transactions on Ultrasonics, Ferroelectrics, and Frequency Control, 2012. **59**(5): p.846-858.
- [2] Beker, L., Kulah, H., and Muhtaroglu, A. *Piezoelectric Cantilever Prototype for Energy Harvesting in Computing Applications*. IEEE Energy Aware Computing (ICEAC), international Conference on Istanbul, 2011. p. 1-4.
- [3] Roundy, S., Leland, ES., Baker, J., Carleton, E., Reilly, E., and Lai, E. *Improving power output for vibration-based energy scavengers*, IEEE Pervasive Computing, 2005. **4**(1): p. 28–36.
- [4] Steven, R., Anton, H., and Sodano, A. *A Review of Power Harvesting Using Piezoelectric Materials*. IOP Publishing, Smart Material Structure, 2007. **16**(3): p. 1-21.
- [5] Soo Kim, H., Hyong Kim, J., and Kim, J. *A Review of Piezoelectric Energy Harvesting Based on Vibration*. International Journal Of Precision Engineering And Manufacturing, 2011. **12**(6): p. 1129- 1141.
- [6] Niell, G., Elvin, G., and Elvin, A. *Vibrational Energy Harvesting From Human Gait*. IEEE/ASME Trans. On Mechatronics, 2013. **18**(2): p. 637-644.
- [7] RummanHuq, T., and Sheldon Williamson, S. *Comprehensive Comparative Analysis of Piezoelectric Energy Harvesting Circuits for Battery Charging Applications*. 39th Annual Conference of the IEEE industrial Electronics Society, IECON 2013. p.6698-6702.
- [8] Abdulmunam, R. T., Taha, L. Y., and Ivey, P. C. *Modelling of Low Power Electrostatic Wind Energy Harvester for Macro-Scale Applications*. International Journal of Information and Electronics Engineering, 2012. **2**(6): p. 912-918.
- [9] Wischke, M., Masur, M., and Woias, P. *A Hybrid Generator for Vibration Energy Harvesting Applications*. IEEE International Solid –State Sensors, Actuators and Microsystems Conference, Transducers, 2009. p. 521-524.
- [10] Taufik, T., Thornton, J., and Taufik. M. *Small-Scale Wind Energy Harvesting Using Piezoelectric Converter*. IEEE Conference on Power Engineering and Renewable Energy, Bali, Indonesia, 2012. p.1-5.
- [11] Sudevalayam, S., and Kulkarni, P. *Energy Harvesting Sensor Nodes: Survey and Implications*. IEEE Communications Surveys and Tutorials, 2011. **13**(3): p. 443-461.
- [12] Mitcheson, P. D., Green, T. C., Yeatman, E. M., and Holmes, A. S. *Power processing circuits for electromagnetic, electrostatic and piezoelectric inertial energy scavengers*. Microsystem Technology, 2007. **13**(11): p. 1629–1635.
- [13] Camila, G. G., Vitor, R. F., Michael, J. B., Samuel, D. S., and Vicente, L. J. *Energy Harvesting Using Piezoelectric and Electromagnetic Transducers*. Proceedings of the 9th Brazilian Conference on Dynamics Control and their Applications 2010. p. 1166-1171.

- [14] Wang, D. A., and Chang, K. H. *Electromagnetic energy harvesting from flow induced vibration*. In: *Microelectronics Journal*, 2010. **41**(6): p. 356–364.
- [15] Vatanserver, D., Hadimani, R., Shah T., and Siores, E. *An investigation of energy harvesting from renewable sources with PVDF and PZT*. *Smart Mater. Struct.* 2011. **20**(5): p. 1-7.
- [16] Elmes, J., Gaydarzhiev, V., Mensah, A., Rustom, K., Shen, J., and Batarseh, I. *Maximum energy harvesting control for oscillating energy harvesting systems*. In *Proc. IEEE Power Electron. Spec. Conference 2007*. p. 2792–2798.
- [17] Gutierrez, A., Dopico, N. I., Gonzalez, C., Zazo, S., Jimnez-Leube, J., and Raos, I. *Cattle-Powered Node Experience in a Heterogeneous Network for Localization of Herds*. *IEEE Trans. on Industrial Electronics*, 2013. **60**(8). p. 3176-3184.
- [18] Mitcheson, P. D., Yeatman, E.M., Rao, G.K., Holmes, A.S., Green, T.C. *Energy Harvesting From Human and Machine Motion for Wireless Electronic Devices*, *Proceedings of the IEEE*, 2008. **96**(9): p. 1457-1486.
- [19] Meninger, S., Mur-Miranda, J. O., Amirtharajah, R., Chandrakasan, A. P., and Lang, J. H. *Vibration-to-electric energy conversion*. *IEEE Trans. Very Large Scale Integr. Syst.*, 2001. **9**(1): p. 64–76.
- [20] Ottman, G. K., Hofmann, H. F., Bhatt, A. C., and Leisure, G. A. *Adaptive piezoelectric energy harvesting circuit for wireless remote power supply*. *Power Electronics*, *IEEE Trans. on*, 2002. **17**(5): p. 669-676.
- [21] Liu, P. G., Wen, Y. M., Li, P., Bian, L. X., Jia, C. B., and Li, X. S. *Study on Power Management Circuit of a Magnetolectric Self-Powered Wireless Sensor*. *Chinese Journal of Sensors and Actuators*, 2008. **21**(8): p. 1427-1431.
- [22] Kwon, D., and Rincon-Mora, G. A. *A Rectifier-Free Piezoelectric Energy Harvester Circuit*. *IEEE International Symposium on Circuit and Systems, ISCAS*, 2009. p. 1085-1088.
- [23] Yin Chen, Y., Vasic, D., Costa, F., Jong Wu W., and Lee, C. K. *Self-powered Piezoelectric Energy Harvesting Device using Velocity control Synchronized Switching Technique*. *IEEE industrial Electronics Society IECON -36th Annual Conference 2010*. p.1785-790.
- [24] Ahmad R. and Hanifah Hashim, M. *Development of Energy Harvesting Device using Piezoelectric Material*. *IEEE 4th International Conference on Modelling, Simulation and Applied Optimization (ICMSAO)*, 2011. p. 1-6.
- [25] Annie Grace, E., Edward Rajan, S., and AllwynclarencAsis, A. *Performance Evaluation of Different Rectifiers for Piezo-electric Energy Harvesting Applications*. *International Conference on Recent Advancements in Electrical, Electronics and Control Engineering*, 2011. p.248-252.
- [26] Ottman, K., Hofmann, H. F., Bhatt, A.C., and Leisure, G. A. *Adaptive piezoelectric energy harvesting circuit for wireless remote power supply*. *IEEE Trans. Power Electron*, 2002. **17**(5):p. 669–676.
- [27] Junrui, L., and Wei-Hsin, L. *An improved self-powered switching interface for piezoelectric energy harvesting*. In *Information and Automation, 2009. ICIA '09. International Conference on 2009*. p. 945- 950.



Biography

Liew Hui Fang is currently pursuing the Ph.D. degree in electrical systems engineering at University Malaysia Perlis (UniMAP), Malaysia. Her area of research is in renewable energy/ Power Energy/ Microwave Communication and RF MEMS. She received the B.S. degree in electrical systems engineering in 2012 and the M.Sc. degree in microelectronics engineering in 2015 from University Malaysia Perlis (UniMAP), Malaysia.



Prof Dr. Syed Idris Syed Hassan is a Professor at School of Electrical System Engineering at University Malaysia Perlis (UniMAP). He obtained his PhD in Antennas and propagation from University of Exeter In 1987. His research interest includes Antenna, RF propagation, Microwave Engineering, Radar, Satellite, EMC, renewable energy and power quality